

STAKKAbox™ ULTIMA and ULTIMA Connect *Installation Guide*



Introduction

Contents

| | | | |
|------------------------------------|-------|-----------------------------------|----|
| Introduction | 02 | Duct Entries | 11 |
| Product Overview | 03 | MULTIduct™ Connections | 12 |
| Table 1 - Installation Guidelines | 04-06 | Trough Connections | 13 |
| EN124 Group | 07 | Overbuilding Existing Services | 14 |
| Frame & Cover Options | 08 | Wall Furniture & Cable Management | 15 |
| Equipment and Additional Materials | 08 | Backfill Bracing | 16 |
| Footprint | 09 | Chamber Backfill | 17 |
| Excavation | 09 | Depth Adjustment | 18 |
| Foundation | 10 | Frame & Cover | 19 |
| Chamber Assembly | 10 | Ground Level Reinstatement | 20 |

Introduction

This guide addresses the method and detail for the installation of the STAKKAbox™ ULTIMA and ULTIMA Connect access chamber system. The purpose is to serve as a guideline, and is not intended for any specific construction project.

It is understood there are alternative ways that might be required and/or recommended based on site or project conditions. Cubis Systems reserves the right to alter these guidelines and encourages contact with the business or its representatives to review any possible modification to these notes prior to commencing installation.



Scan here to download technical resources, BIM level 2 models, videos and product information

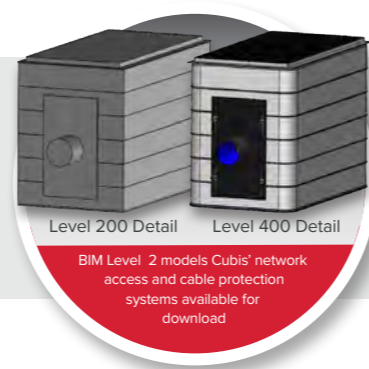

Product Overview

The STAKKAbox™ ULTIMA and ULTIMA Connect are modular scalable solutions which can be prebuilt in a Cubis factory or built on-site with easily connectable components. Significantly reducing costs of in-situ construction through time savings, the light weight chamber systems feature twin wall sectional designs that are made up of GRP (glass reinforced polymer composite). The ULTIMA Connect

consists of corner components (known as 'hockey sticks') and sidewall lengths. These components are connected using a jointing peg to form a variety of clear opening sizes. With sidewall lengths being used in conjunction with corner components additional chamber sizes specified by the contractor can be made.

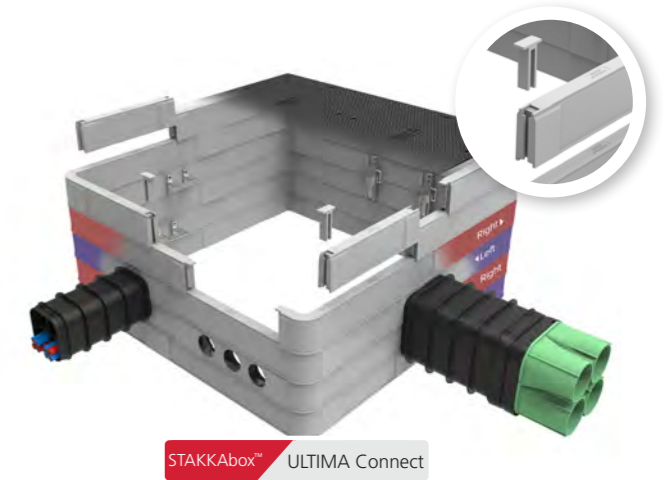

Strength

Vertically load rated to F900, and offers excellent sidewall strength.

Smooth Outer Walls with Lip to 'Key In'

STAKKAbox™ chambers have smooth outer walls and an outer lip which aids keying the chamber into the backfill.

Lightweight

Due to the sectional twinwall design and the GRP material both ULTIMA and ULTIMA Connect have 150mm deep ring sections and ULTIMA Connect components are under 10kg in weight.

Fast and Easy to Install

ULTIMA Connect chambers are significantly faster to install than traditional alternatives, with complete installations typically taking up to one hour. This results in reduced costs for the installer.

How it's Built

ULTIMA Connect corner components are manufactured in left and right 'handed' designs, which offer the ability to offset joints between ring sections in order to provide a brickworked design.

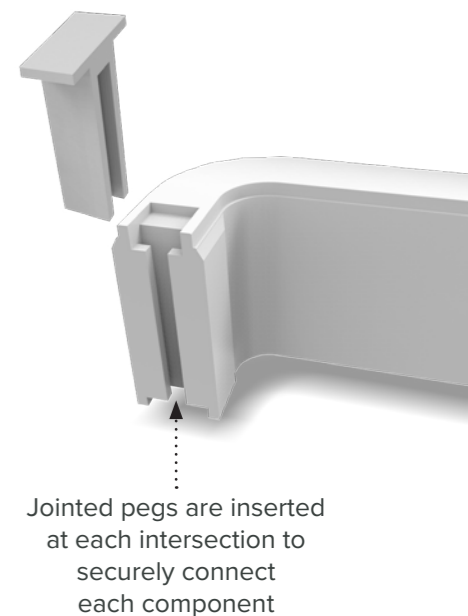
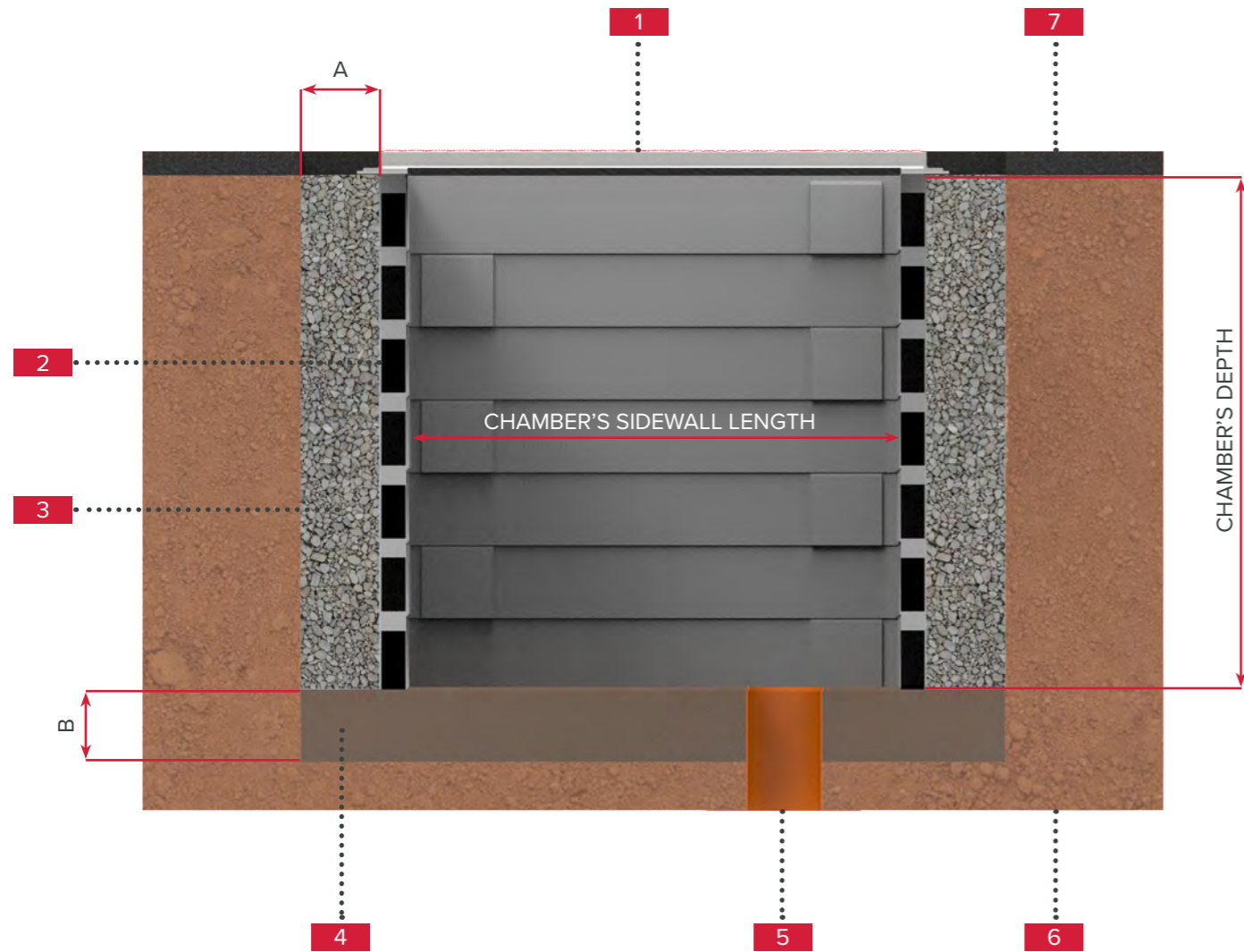

Table 1 - Installation Guidelines

| Product | | ULTIMA & ULTIMA Connect NOTE: Guidelines apply to ULTIMA / ULTIMA Connect chamber depths ≤ 2400mm ^[1] | | | | | | | | |
|--|--|---|--|--|--|----------------------|---|---|----------------------|---|
| EN124 Group (Refer Fig.1) | 1 & 2 | | | 3 | | | 4 & Trackside Areas | | | |
| Group Description | For use in pedestrian areas where there is only occasional vehicular access | | | Areas with controlled, slow-moving traffic, such as car parks (excluding carriageways) | | | For use in areas where cars and lorries have frequent access, including carriageways, hard shoulders and the track support zone | | | |
| Backfill Bracing | Chamber sidewall > 1000mm but ≤ 2000mm requires single central bracing Chamber sidewall > 2000mm requires bracing for every 1000mm interval as a minimum Cross bracing should be the full depth of the chamber | | | | | | | | | |
| Backfill ^{[2],[3],[4],[5]} | Sidewall Length | ≤ 1310mm | > 1310mm to ≤ 1800mm | > 1800mm to ≤ 2500mm | ≤ 1310mm | > 1310mm to ≤ 1800mm | > 1800mm to ≤ 2500mm | ≤ 1310mm | > 1310mm to ≤ 1800mm | > 1800mm to ≤ 2500mm |
| | Base Material & depth | 100mm of well compacted granular material | 100mm of dry lean mix concrete (CBM 4) | | 100mm of dry lean mix concrete (CBM 4) | | 150mm of dry lean mix concrete C20 | 150mm of dry lean mix concrete C20 | | 150mm of dry lean mix concrete C20 with A393 mesh |
| | Material Type & Width of Backfill | Minimum of 100mm of well compacted granular material (i.e. Type 1 or similar) | | Minimum of 150mm of well compacted gravel material | Minimum of 100mm of well compacted granular material | | Minimum of 150mm of well compacted granular material (i.e. Type 1 or similar) | Minimum of 150mm of well compacted granular material (i.e. Type 1 or similar) | | Minimum 100 mm C30 concrete surround |
| NOTE 1: These are generic installation guidelines and Cubis recognises that installation conditions may vary by project – please contact Cubis technical if you wish to discuss your project requirements. For chamber sizes that are > 2500mm in side wall length and > 2400mm in depth please contact the Cubis Systems Technical department, technical@cubis-systems.com. | | | | | | | | | | |
| NOTE 2: The backfill requirements for each EN124 Group relates to where the chamber will be installed, rather than the load rating on the cover. Therefore, if a chamber is specified with a D400 rated cover but will be installed in the footway, the backfill requirements for a chamber installed in a footway apply. | | | | | | | | | | |
| NOTE 3: Minimum Excavation Footprint, 100mm to 200mm (depending on specified backfill) or width of compacting equipment, whichever is greater. | | | | | | | | | | |
| NOTE 4: Type 1, also known as MOT1/DOT Type 1, can be made from Granite, Limestone or clean Crushed Concrete. The product is crushed to 40mm down to dust creating an aggregate containing a range of particle sizes in compliance with the Department of Transport Specification for Highway Works, clause 803 (SHW 803). | | | | | | | | | | |
| NOTE 5: Calculations are based on a 28 day strength, if the chamber is to be subjected to vehicular traffic prior to this, the concrete strength should be altered to accommodate the required timeline. | | | | | | | | | | |
| NOTE 6: CBM4 has a minimum of 1:2:4 cement:sand:aggregate ratio | | | | | | | | | | |

Table 1 - Installation Guidelines Continued

| Product | | ULTIMA & ULTIMA Connect NOTE: Guidelines apply to ULTIMA/ULTIMA Connect chamber depths ≤ 2400mm ^[1] | | | |
|---|--|---|---|---|-----------------------|
| EN124 Group (Refer Fig.2) | 5 | | 6 | | |
| Group Description | For use in areas where high wheel loads are imposed such as loading areas for docks. | | For use in areas where extremely high wheel loads are imposed such as aircraft pavements. | | |
| Backfill Bracing | Chamber sidewall ≤ 1000mm but ≤ 2000mm requires single central bracing Chamber sidewall > 2000mm requires bracing for every 1000mm interval as a minimum Cross bracing should be the full depth of the chamber | | | | |
| Backfill ^{[2],[3]} | Sidewall Length | ≤ 1310mm | > 1310mm | ≤ 1310mm | > 1310mm |
| | Base Material & Depth | 150mm of dry lean mix concrete C20 | Contact Cubis Systems | 150mm of dry lean mix concrete C20 with A393 mesh | Contact Cubis Systems |
| | Material Type & Width of Backfill | Minimum of 150mm of well-compacted granular material (i.e. Type 1 or similar) | Contact Cubis Systems | Minimum 100mm C30 concrete surround | Contact Cubis Systems |
| NOTE 1: For chamber sizes that are > 1310mm in side wall length and > 2400mm in depth please contact the Cubis Systems Technical department, technical@cubis-systems.com. | | | | | |
| NOTE 2: The backfill requirements for each EN124 Group relates to where the chamber will be installed, rather than the load rating on the cover. Therefore, if a chamber is specified with a D400 rated cover but will be installed in the footway, the backfill requirements for a chamber installed in a footway apply. | | | | | |
| NOTE 3: Minimum Excavation Footprint, 100mm to 200mm (depending on specified backfill) or width of compacting equipment, whichever is greater. | | | | | |



| | Items | Notes |
|---|------------------------|--|
| 1 | Frame & Cover | Dimensions to suit project specification |
| 2 | ULTIMA Connect Chamber | Dimensions to suit project specification Chamber's sidewall length and depth |
| 3 | Backfill | See Table 1 (Material Type / Width of Backfill) above for material and dimension A |
| 4 | Base | See Table 1 (Base Material) above for material and dimension B |
| 5 | Drainage Soakaway | Optional |
| 6 | Existing Ground | |
| 7 | Surface Material | |

- 1 Group 1**
 Pedestrian access only (Footway)
- 2 Group 2**
 For use in pedestrian areas where there is only occasional vehicular access
- 3 Group 3**
 For use in car parks and areas with slow moving traffic. (excluding carriageways)
- 4 Group 4**
 For use in areas where high wheel loads are imposed such as loading areas for docks.
- 5 Group 5**
 For use in areas where high wheel loads are imposed such as loading areas for docks.
- 6 Group 6**
 For use in areas where extremely high wheel loads are imposed such as aircraft pavements.

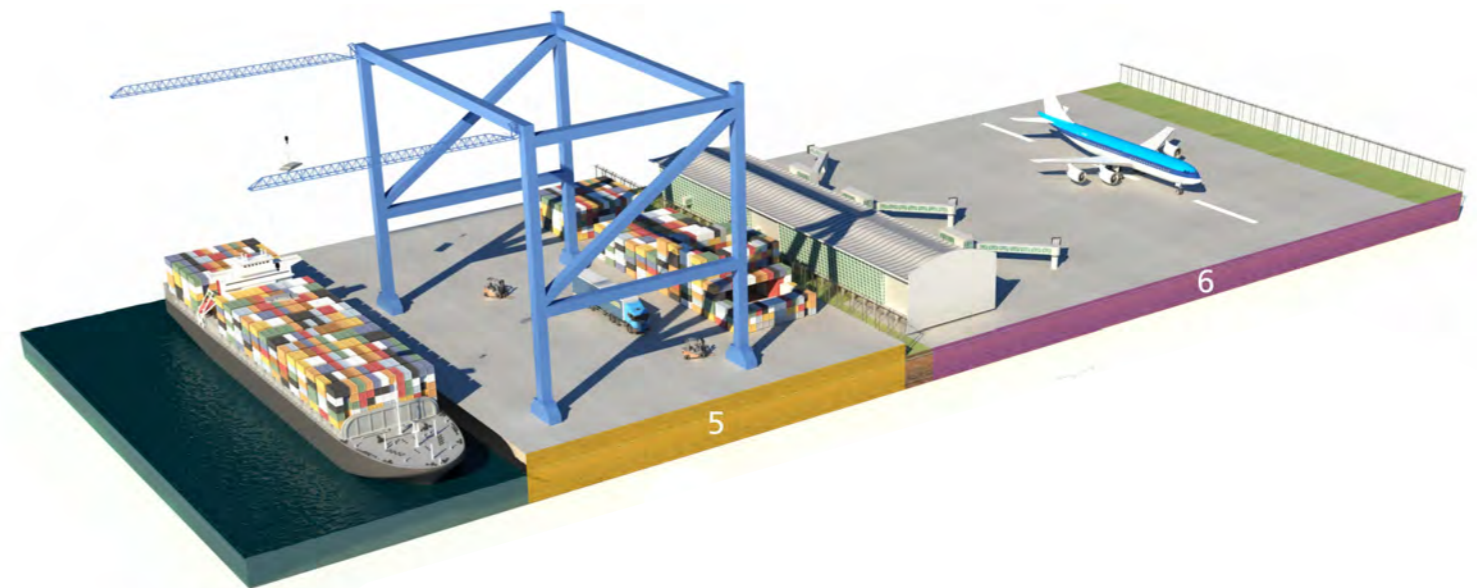

Frame & Cover Options

Cubis manufacture a range of frames and covers engineered to work seamlessly with its STAKKAbox™ network access chambers. If a frame and cover is being installed, it must be specified to the correct loading as dictated by EN124 and site requirements.

If you have any queries, please contact Cubis Systems.

Concrete Infill



Recessed



Composite

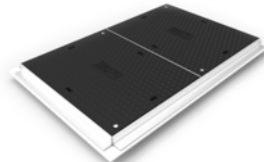

Ductile



Equipment and Additional Materials

In addition to the STAKKAbox™ supplied, in order to complete an installation you will need the following:

- | | |
|--|------------------------------|
| 1 The means of excavating a hole; mechanical digger, pneumatic hammer etc. depending on the ground conditions and size of chamber being installed | 4 Builders trowel |
| 2 Shovel or spade | 5 Straight edge/level |
| 3 Means of compacting base and surrounding material | |

Materials Required

- | |
|------------------------------|
| 1 Base materials |
| 2 Backfill material |
| 3 Bedding mortar |
| 4 Bracing if required |

If cutting a chamber, the below are required:

- | |
|-----------------------------|
| 1 Dust mask |
| 2 Hole saw |
| 3 Saw or Disk cutter |
| 4 A power drill |

Installation Procedure

Footprint

- 1** Mark the extremity of the excavation on the ground.

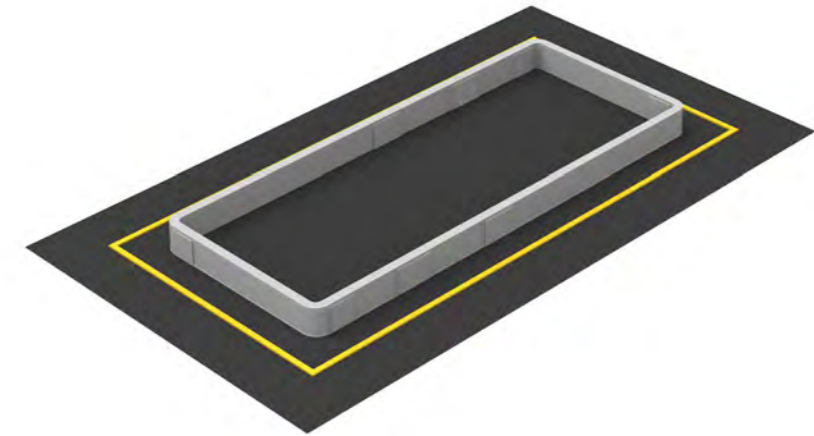

Excavation

- 2** Excavate to the correct depth.
- 2.1** Consider the depth of the base, frame, and bedding mortar.



Installation Procedure

Foundation

- 3** Compact the bottom of the excavation.
- 3.1** Remove soft areas, fill with suitable materials, and compact.^[1]
- 4** Construct the chamber foundation.
- 4.1** Install drainage if required.
- 5** Construct^[3] and place the bottom ring section on the base.
- 5.1** Where possible key in bottom ring into the base.
- 5.2** Ensure the ring section is level.



Chamber Assembly

- 6** Construct the remainder of the chamber.^[3]

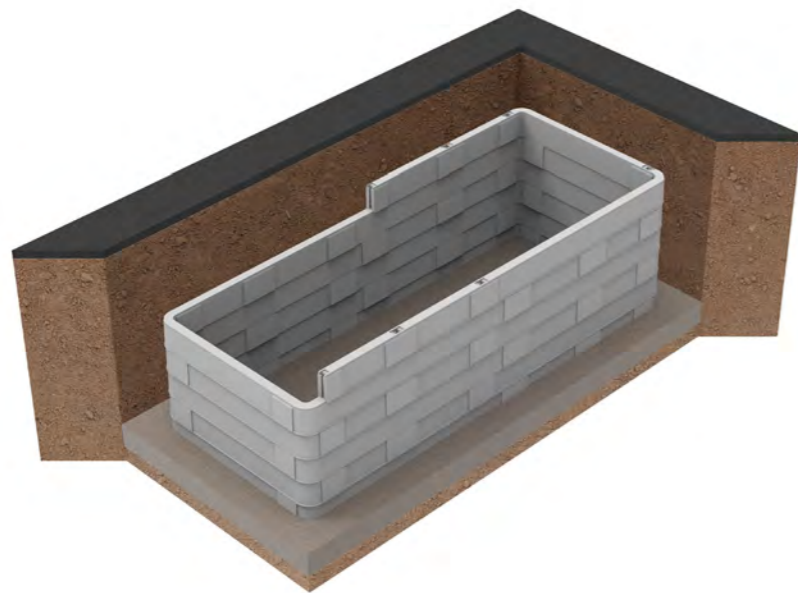

Installation Procedure

Duct Entries

- 7** Guideline restrictions when forming duct entries are shown below. Contact Cubis to provide guidance on duct entries which exceed these restrictions.
- 7.1** Duct entries can be preformed in a Cubis factory or formed on site.
- 7.2** Site formed duct entries can be formed by two methods. Using a hole saw^[2] (A) or using a saw to form a rectangular opening. (B)
- 7.2.1** If required duct entries can be cut across two or more sections.
- 8** Duct entries up to 120mm in diameter can be drilled in every ring section but the top and bottom ring sections of the chamber should be left intact. (C)
- 9** As a rule of thumb allowable distance between ducts should be half of the diameter of the largest duct entry. (D)
- 10** Insert ducts.
- 10.1** Fill gaps as per site requirement to prevent ingress from backfill.

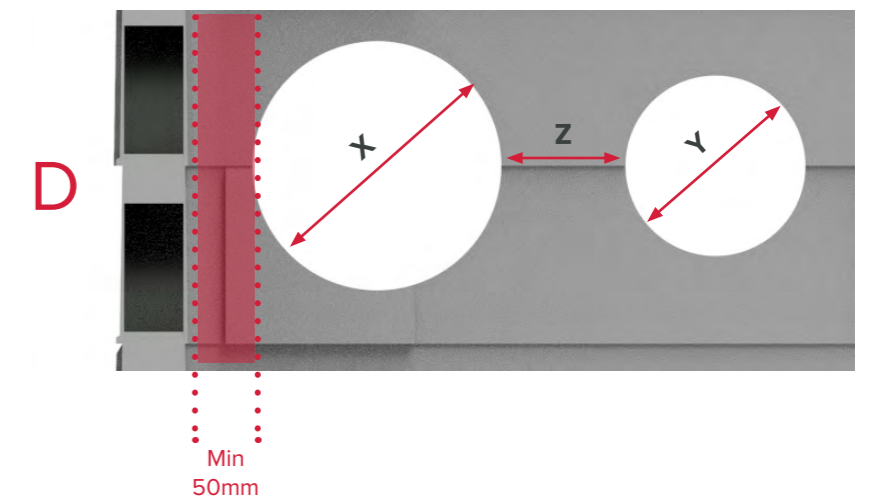
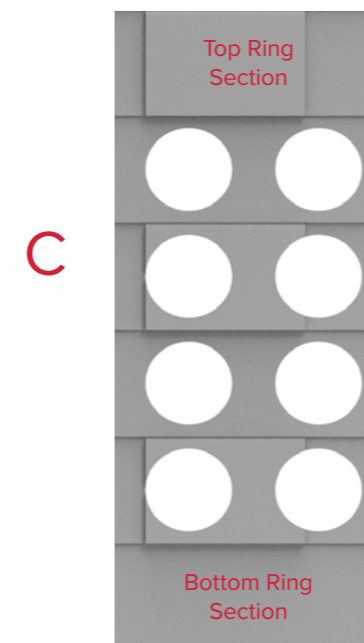
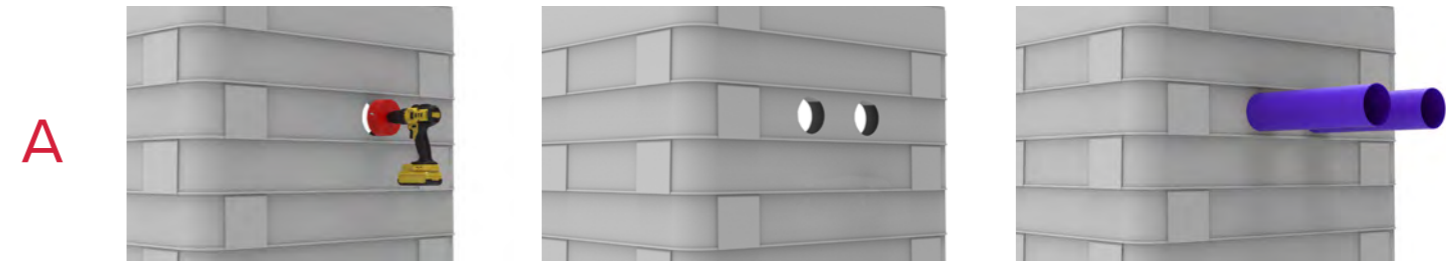

X: Larger Diameter
Y: Smaller Diameter
Z (Duct Spacing): Half of Larger Diameter (X)

Installation Procedure

MULTIduct™ Connections

- 11** Guideline restrictions when forming MULTIduct™ connections are shown below. Contact Cubis to provide guidance on MULTIduct™ connections which exceed these restrictions.
- 11.1** MULTIduct™ connections can be preformed and fixed in a Cubis factory or formed and fixed on site.
- 11.1.1** Factory formed connections are supplied with an installed spigot or socket connection which is ready to plug into a MULTIduct™ run.
- 11.2** Site formed connections can be formed by two methods.
 - 11.2.1** Using a hole saw⁽²⁾ and power drill to form four round corner openings, then cutting out the remainder using an electric saw. (A)
 - 11.2.2** Using an electric saw to form a rectangular opening. (B)
- 12** Where possible the ring sections above and below the MULTIduct™ should remain intact.
- 13** Insert MULTIduct™.
- 14** Fill gaps as per site requirement to prevent ingress from backfill.

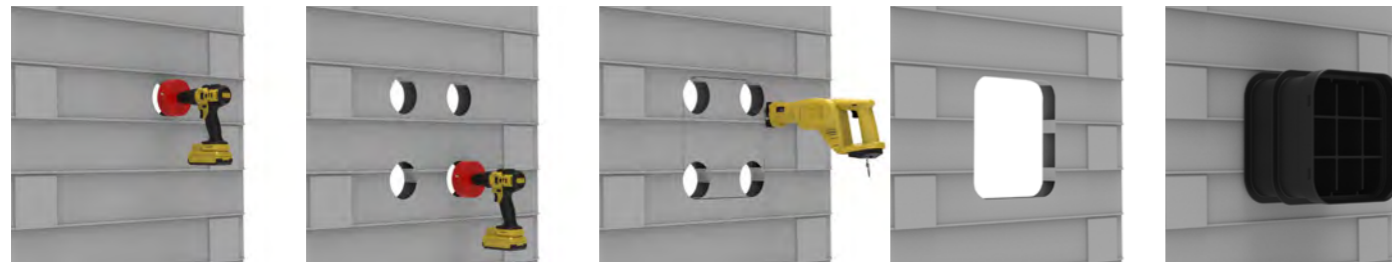

A

B

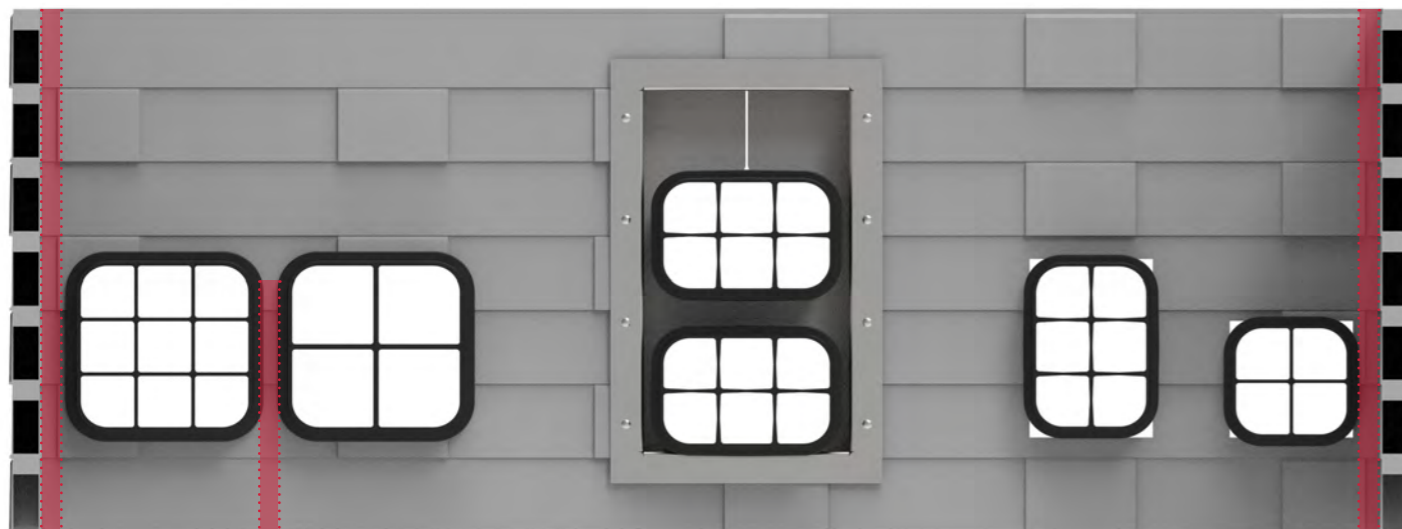

Min 50mm Min 50mm Min 50mm

Minimum of 50mm from internal edge of chamber

Installation Procedure

Trough Connections

- 15** Form trough connections if required
- 15.1** Guideline restrictions when forming trough connections are shown below. Contact Cubis to provide guidance on trough connections which exceed these restrictions.
- 16** Site formed entries can be formed using a saw and/or a disk cutter to cut a rectangular opening in the chamber wall.
- 16.1** Cut the trough body corner to fit the frame before inserting it in the chamber.
- 16.2** Position the trough end so it is flush with the chamber inner wall.
- 17** Cut the trough cover back so it is flush with the flange of the frame.
- 18** Fill gaps as per site requirement to prevent ingress from backfill.

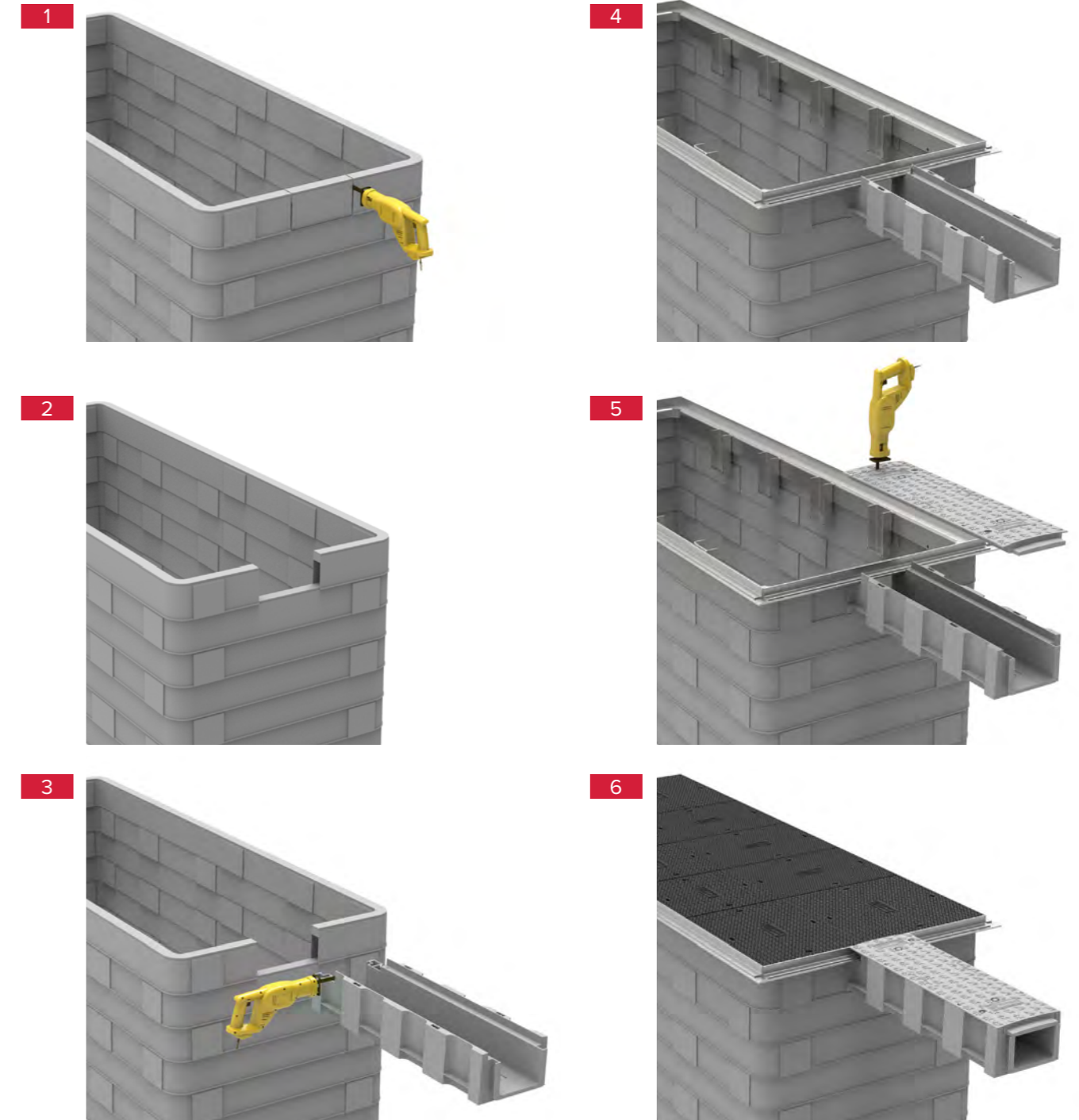

Installation Procedure

Overbuilding Existing Services

- 19** Alter chamber for existing services if required.
 - 19.1** Use a hole saw^[2] and power drill to form a typical duct entry, then cutting out below the duct entry using an saw to create an open-ended arch in a ring section.
 - 19.1.1** Use an saw to form a rectangular opening.
 - 20** Build chamber over services.
 - 21** Fill gaps as per site requirement to prevent ingress from backfill.
 - 22** The top and bottom ring section of the chamber should be kept complete.
- However deviations are permissible under certain circumstances. Please contact Cubis for further guidance.

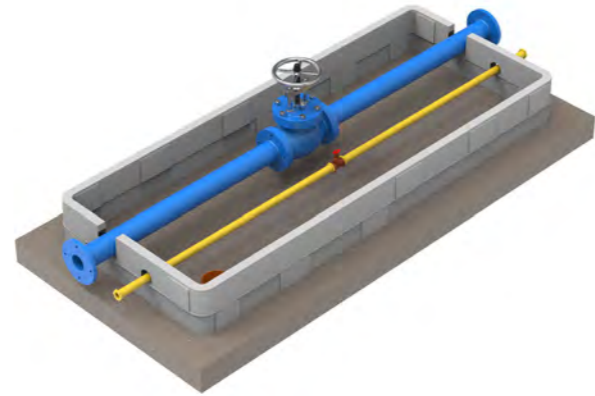

Cut Duct Entry

Arched Cut Duct Entry

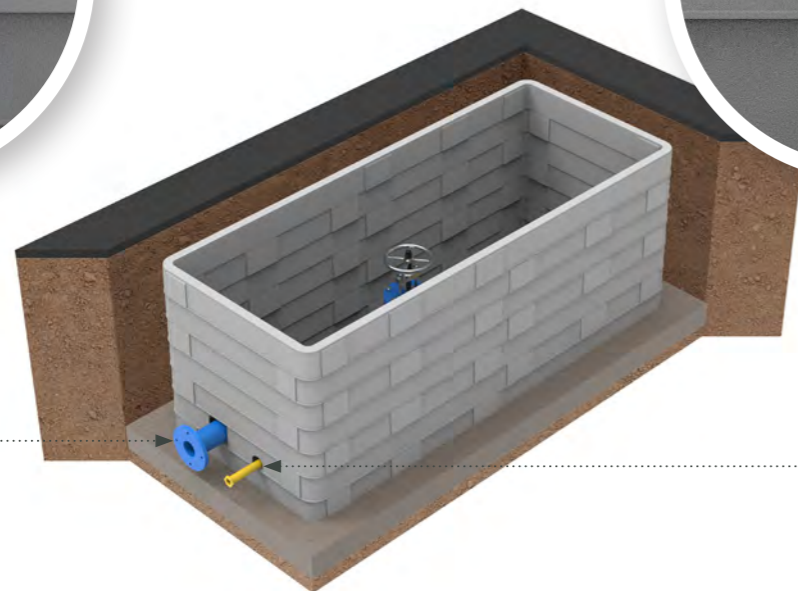
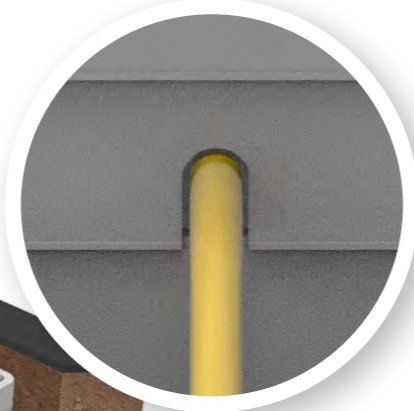

Installation Procedure

Wall Furniture & Cable Management

- 23** Install accessories if required.
- 23.1** Wall furniture and cable management can be pre-installed in a Cubis factory or installed on site. Wall furniture should be installed before backfill when installing on site.
- 23.1.1** Position as per the client's specifications and fix to the chamber. (Using M12 fixings supplied with kits).
- 23.1.1.1** Consider the final position of the frame (especially cross beams and cross pieces) when installing accessories to avoid clashes.

Cable Bracket



Wall Bearer

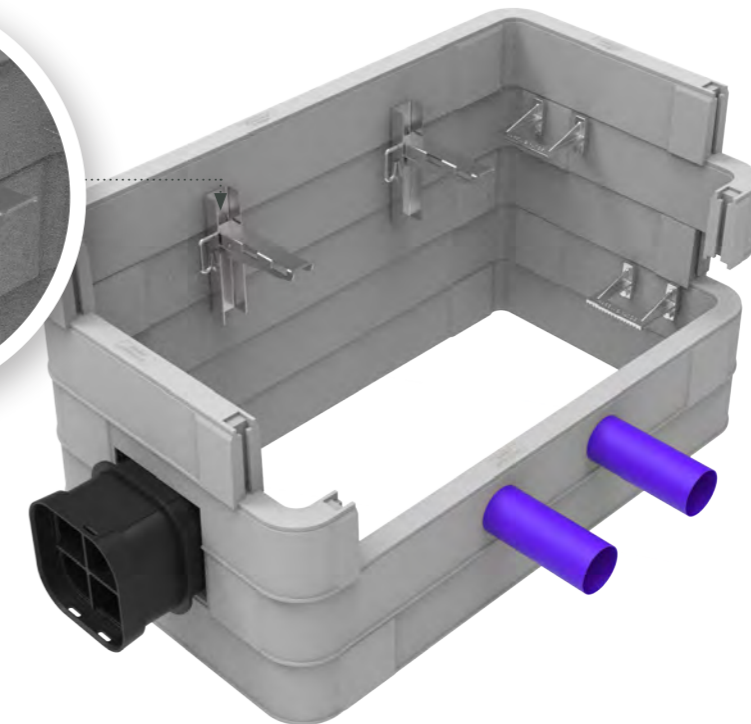
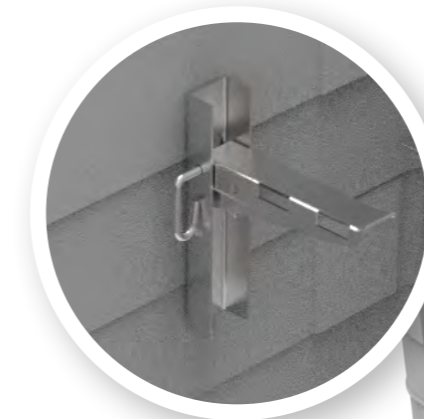

Installation Procedure

Backfill Bracing

24 Install temporary bracing if required.

24.1 Use scaffold board or timber/wood to spread load along chamber depth if using Acrow props to disperse the load evenly across the chamber wall.

24.2 Make sure internal chamber dimensions are correct once braced. Take care to avoid under or over bracing.

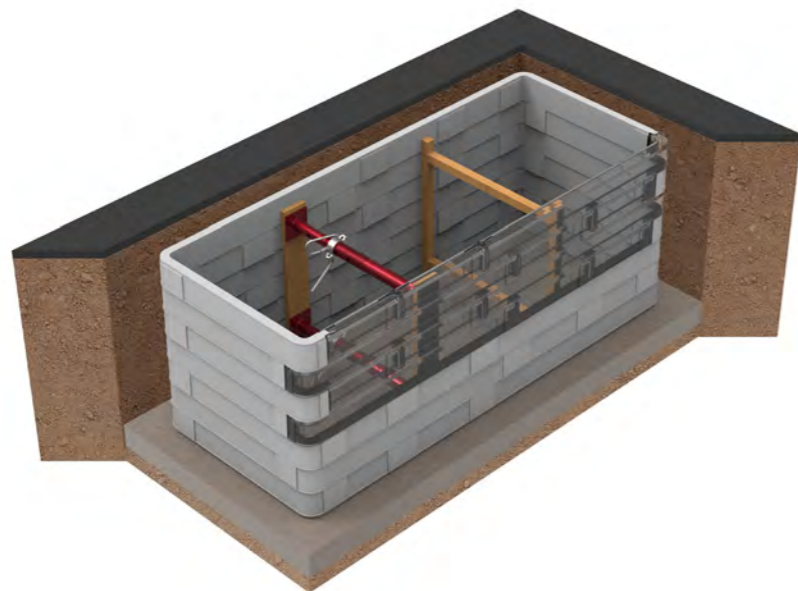
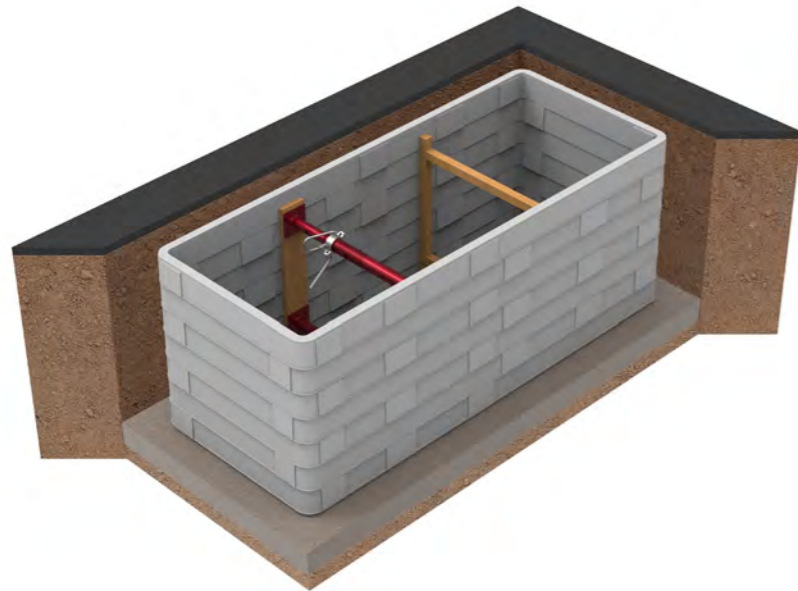

Installation Procedure

Chamber Backfill

25 Complete the backfill to the top of the chamber or base of the pavement construction.

25.1 Granular backfill must be built in well compacted layers^[1].

25.2 Concrete backfill must be appropriately compacted.

26 Leave bracing in place until the backfill is complete.

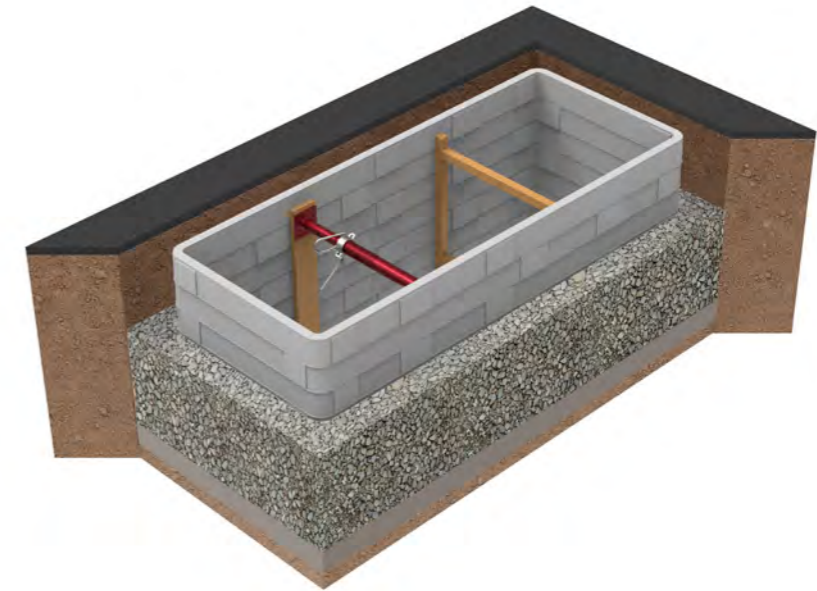

Installation Procedure

Depth Adjustment

- 27** If the chamber depth has been miscalculated and cannot be corrected by packing under the frame it is possible to cut the top ring section down to the correct level.
- 28** Fill the voids of the top ring section to provide a solid base for the frame to be bedded onto.



Installation Procedure

Frame and Cover

- 29** Check the required mortar bed depth.
- 30** Apply the mortar bed.
- 30.1** Loading environments of D400 require a appropriate mortar with a minimum tensile strength of 5N/mm²(1).
- 30.2** The bed should be 10mm higher than required and 25mm wider than the spread of the underside of the frame.
- 31** Place the frame on the mortar bed.
- 31.1** Ensure it is aligned with the chamber.
- 32** Tap the frame so that it beds into the mortar bed.
- 32.1** Ensure it is aligned with the finished ground level.
- 33** Apply mortar over the exterior flanges of the frame. See mortar detail below.
- 34** Remove excess mortar.
- 35** Gently place the beams and covers into the frame while the mortar bed cures.

Mortar Detail



Ground Level Reinstatement

- 36** Complete the ground construction to the finished surface level as per the client's specifications^[1].



Notes

- [1]** As per the requirements of "Specification for the Reinstatement of Openings in Highways - Appendix A8" or equivalent national standard.
- [2]** Preferably diamond tipped – available from Cubis.
- [3]** As per the ULTIMA and ULTIMA Connect Assembly Guides.
- For advice and guidance beyond the specifications of this Installation Guide please contact a Cubis representative.

Cubis makes no express or implied warranty or guarantee of the techniques, construction methods or materials identified herein.

The customer shall comply with all laws, regulations, codes and orders of any authority having jurisdiction over the customer and which relate to the customer's installation, maintenance and use of Cubis products. If the customer's installation or use of any products contravenes any such laws, regulations, codes or orders of such authorities, the customer shall be responsible for the violations thereof and shall bear the costs, expense and damages attributable to its failure to comply with the provisions of such laws, ordinances, rules, regulations, codes or orders.

Reproduction of the material herein is not permitted without the written consent of Cubis Systems.



Driven by Innovation

Innovation is the engine that has driven Cubis Systems to its position as global leader in the design and manufacture of access chambers and cable ducting systems.

Inspired by innovation, we have developed quality products that replace traditional construction materials like bricks and concrete. Our lightweight plastics, incorporating intelligent design features, are used in the construction of infrastructure networks for the rail, telecoms, water, construction and power markets worldwide. Cubis products can be installed much faster than traditional methods and therefore save our customers both time and money.

Cubis manufactures the preformed STAKKAbOX™ network access chamber systems, the AX-S™ access covers range, a MULTIduct™ multiple duct system and the PROtrough cable troughing system at sites throughout the UK and Ireland. These innovative products are exported to more than 25 countries throughout the world.

At Cubis we are committed to ongoing innovation and dedicated to delivering absolute product quality, detailed technical customer support and the highest levels of customer satisfaction.

Contact Cubis:

Head Office:
4 Silverwood Industrial Estate,
Lurgan, Co. Armagh,
BT66 6LN,
Northern Ireland

Telephone: +44 (0)28 38 313 100
Email: info@cubis-systems.com
Web: www.cubis-systems.com

